

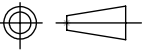

MACHINE:	H49-9	ASME Y 14.5M 1994 APPLIES DRAWING SPECIFIES THE COMPLETE PART REQUIREMENT  THIRD ANGLE PROJECTION LINEAR TOLERANCES: X = ± 0.05 XX = ± 0.01 .XXX = ± 0.003 ANGULAR TOLERANCES ± 1° CHAMFER TOLERANCES ± .5° REMOVE ALL BURRS & SHARP EDGES .002 - .020 X 45° MAX SURFACE FINISH 125✓	 H49-4	
POWER:	220 V. 3 Ph			SIZE PART NO. <b>B</b> H49-9 FOOTPRINT REV. <b>A</b>
AIR PSI:	90 - 110			
DUST PORTS:	1X 3"			
DUST CFM:	350		SCALE:1:24	DO NOT SCALE DRAWING